

NVE

Challenger Series

VACUUM PUMPS & BLOWERS

866

Heavy Duty Vacuum Pumps



Fan Cooled

520 CFM



Liquid Cooled

**Fan or Liquid Cooled
Options Available**

Product Features:

- Proven crash protection allowing all major components to survive a catastrophic failure
- Four point automatic lubrication system
- Liquid or fan cooled versions of each model
- Multiple drive options (gearbox, belt, hydraulic, and direct)
- Integral, easily accessible, final filter
- Vane flush port with valve
- Vane wear inspection port
- Thermometer to monitor exhaust temperature
- Lifetime warranty against cracked housing
- Two year warranty against manufacturer defect
- *Designed, built, and supported in the USA*

Reliable – Efficient – Cost Effective

National Vacuum Equipment



Locations in Michigan & Texas

800-253-5500 | 800-998-6834 FAX | sales@natvac.com

natvac.com

Challenger Series

VACUUM PUMPS & BLOWERS

866 Challenger Fan Cooled

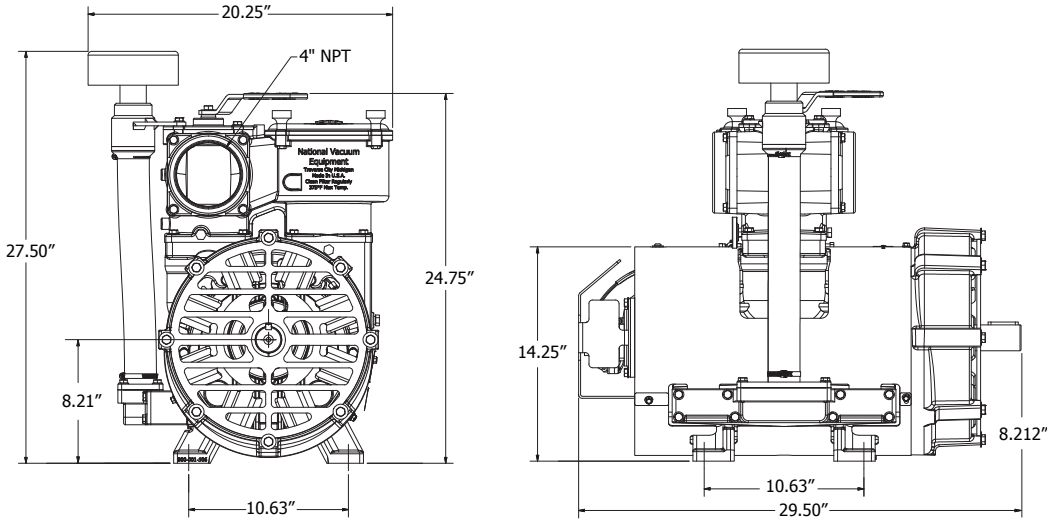

866 Challenger Liquid Cooled

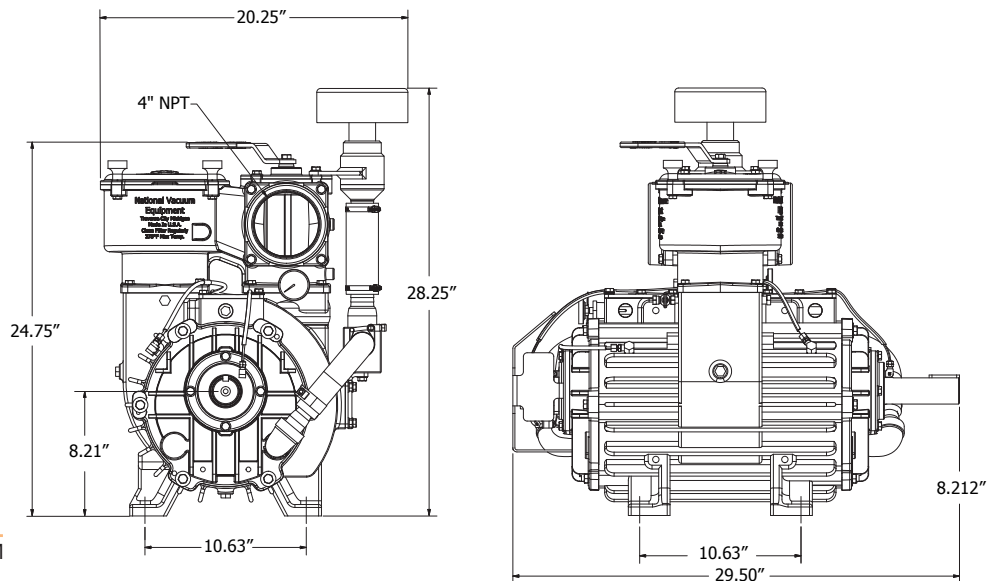

866 Challenger Specifications

Air Flow @ Free Air.....	520 CFM
Maximum Vacuum	27" Hg
Maximum Intermittent Pressure	20 PSI
Operating Speed - Recommended.....	950 RPM
Operating Speed - Intermittent.....	1,150 RPM
HP Required @ 27" Hg.....	29
HP Required @ 10 PSI	27
HP Required @ 15 PSI	36
HP Required @ 20 PSI	45
Porting Size.....	4"
Shaft Size (3/8" Key).....	1 3/4"
Approximate Weight	514 lbs

* Images & specifications for reference only

Please see set up & operation guide for operating parameters.